



# TECHNOMETAL

SHELVING & RACKING SYSTEMS

## Contact us

 **Mob# :** (+2) 0128 3030 147 - (+2) 0120 51 87 552 - (+2) 0120 52 444 94

 **Email :** info@technometalegypt.com - **Postal code :** 44916

 **Add# :** Egypt, 10th of Ramadan city, Industrial zone (A5), Plot No.86

    [www.technometalegypt.com](http://www.technometalegypt.com)



# TECHNOMETAL

SHELVING & RACKING SYSTEMS



## CREATIVE RACKING SYSTEMS

Techno-metal is one of the market leaders in Egyptian market of the field of design and manufacturing the storage systems

[www.technometalegypt.com](http://www.technometalegypt.com)





## Contents

### Racking Systems

	Page
● About us	1
● Racking system components	3
● Pallet racking system	5
● Drive-In racking system	7
● Pallet shuttle system	9
● Gravity system	11
● Mezzanine structure system	13
● Multi-tier racking system	14
● Cantilever racking system	15
● Mobile pallet racking	17
● Self support system (Rack-support building)	19
● Automated vertical storage (SILO2 - ICAM)	21
● Mobile shelving system	22

### Administration

● Mobile Shelving units	23
● Lockers	24
● Some of our works	25

# About us

## Who we are ?

Techno metal is the market leader in Egypt for the local design, manufacture and installation of bespoke commercial storage systems. Established in 2004, our industry expertise means we can bring a wealth of experience to your project. Our design and technical teams will work with you to refine your vision to ensure that your completed project meets your exact needs. Techno metal offers full in-house CAD-CAM design and production to meet the needs of the most challenging projects.

## What we do ?

Our designed storage systems are perfect for use in a wide variety of industries including

- FMCG sector
- Manufacturing storage
- Warehouses
- Pharmaceutical sector
- Archival storage
- Banks & Administration Sector
- Medical Sector
- Schools & Universities
- Hotels & Clubs
- Museums

All the above sectors have benefited from our secure storage systems and the additional space that our solutions can provide

## Our vision

Enlarging our market share in Egypt beside existing strongly in Africa and GCC

## Our Mission

Participating in the mega projects and providing the best storage solutions to facilitate the success for our clients

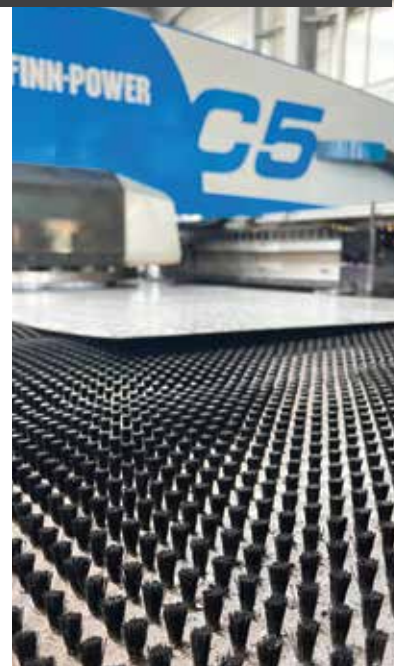

# Our Accredited Certificates

We are proud to be certified in quality management system ISO 9001, Environmental management system ISO 14001 and health and safety environment ISO18001.

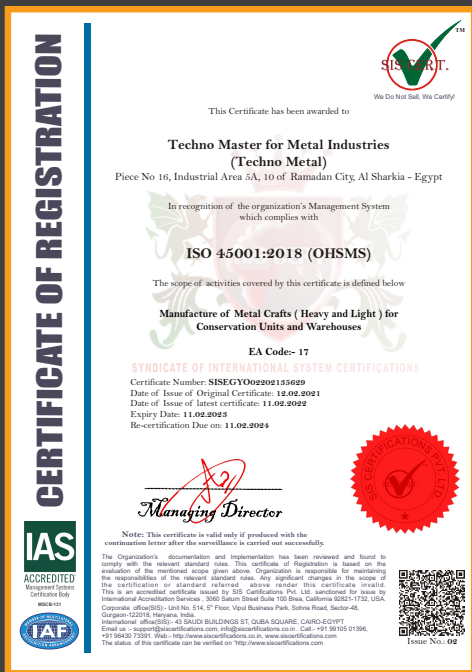

## Uprights

Technometal has 3 types of uprights as follow

- **HEAVY**  
Fabricated in 3 versions, with steel thickness of 2 mm, 2.5 mm, and 3mm. width 12cm
- **MEDIUM**  
Fabricated in 2 versions, with steel thickness of 1.5 mm and 2 mm. width 10cm
- **LIGHT**  
Fabricated in 2 version, with steel thickness of 1.25 mm and 1.5 mm . width 8cm

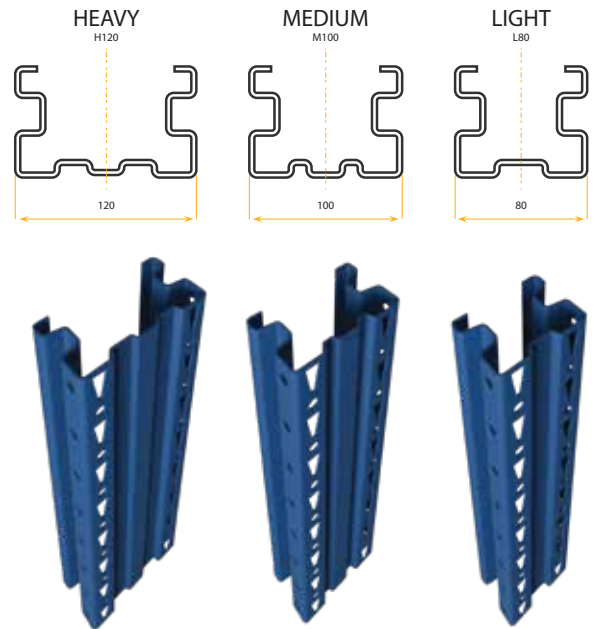

## Beams

Beams are the horizontal, robust racking components where loads are deposited, they are joined to the uprights via connectors which fit into the slots on the upright.

The hooks on these connectors are joined to the main rack structure at both ends

Model 2C	Height mm	Width mm	Thickness mm
	70	50	1.25 & 1.5
	90	50	1.25 & 1.5
	100	50	1.25 & 1.5
	110	50	1.25 & 1.5 & 2
	120	50	1.5 & 2
	140	50	1.5 & 2
	160	50	1.5 & 2



NO.	DESCRIPTION
1	BEAM
2	UPRIGHT
3	FOOT PLATE
4	FOOT PLATE SHIM
5	TUBE BRACING
6	BEAM SAFETY PIN



A  
Connector  
Opposite Tongue Orientation



B  
Beam Safety Pin

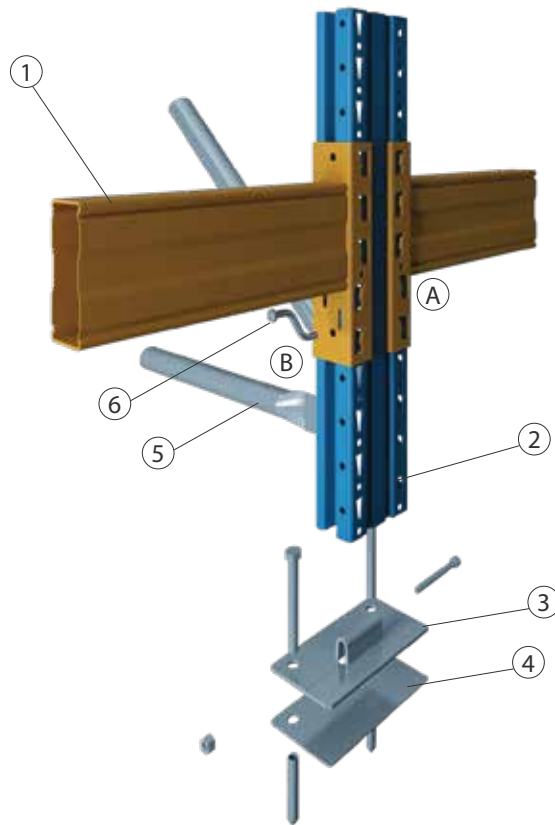

## Pallet racking sections

NO.	DESCRIPTION
1	FRAME
2	BEAM
3	FRAME SPACER
4	WALL SPACER
5	GALVANIZED PICKING SHELF
6	FRAME BRACING
7	UPRIGHT PROTECTOR
8	FRAME BARRIER
9	FOOTPLATE ASSEMBLY
10	PALLET BACK STOPPER ASSEMB
11	DRUM SUPPORTS
12	PALLET SUPPORT BAR
13	RAISED PALLET SUPPORT BAR
14	TUBULAR DIVIDER

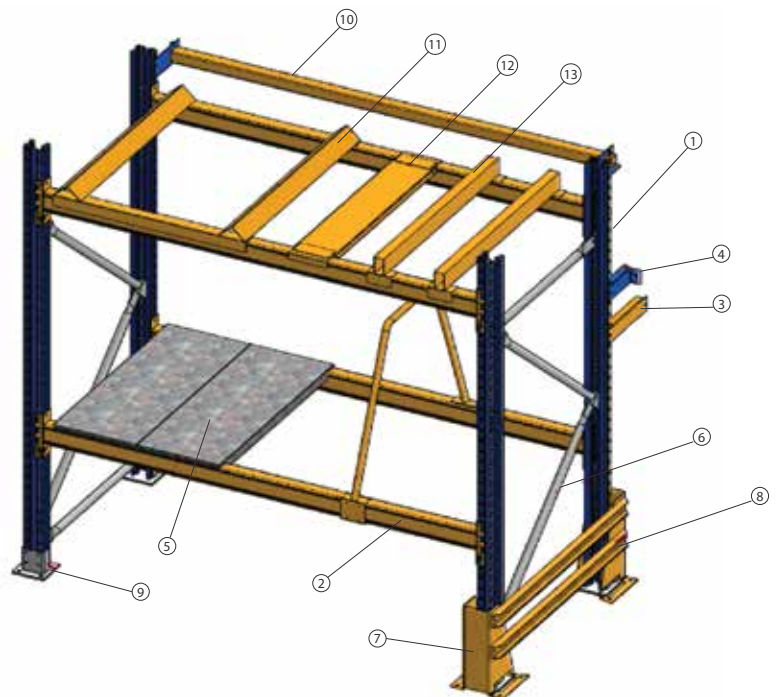



## Pallet racking system

### Advantages

- Perfect solution for direct access to each pallet.
- Maximum adaptability for both pallet weight and volume.
- Can be integrated with other handling and picking solutions.
- Offers great flexibility in product management

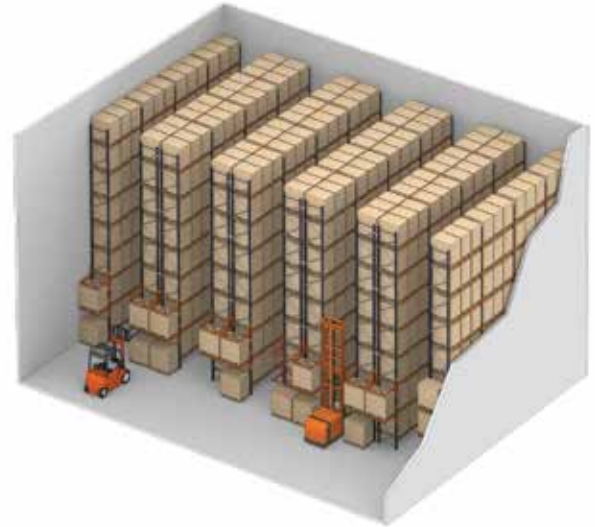

### Pallet racking types

- Selective pallet racking system (wide aisle type).
- VNA racking system (narrow aisle type)
- Double deep racking

### Description

is the most widespread system for sorting and directly accessing each pallet.

It is designed to be compatible with Euro and industrial pallet dimensions weather for flat pallets, mesh box pallets or other loading units.

Techno-metal designs and manufactures pallet racking system to be the basic element used to assemble drive-in, gravity, automatic storage, Mobile pallet racking and self supporting storage systems.

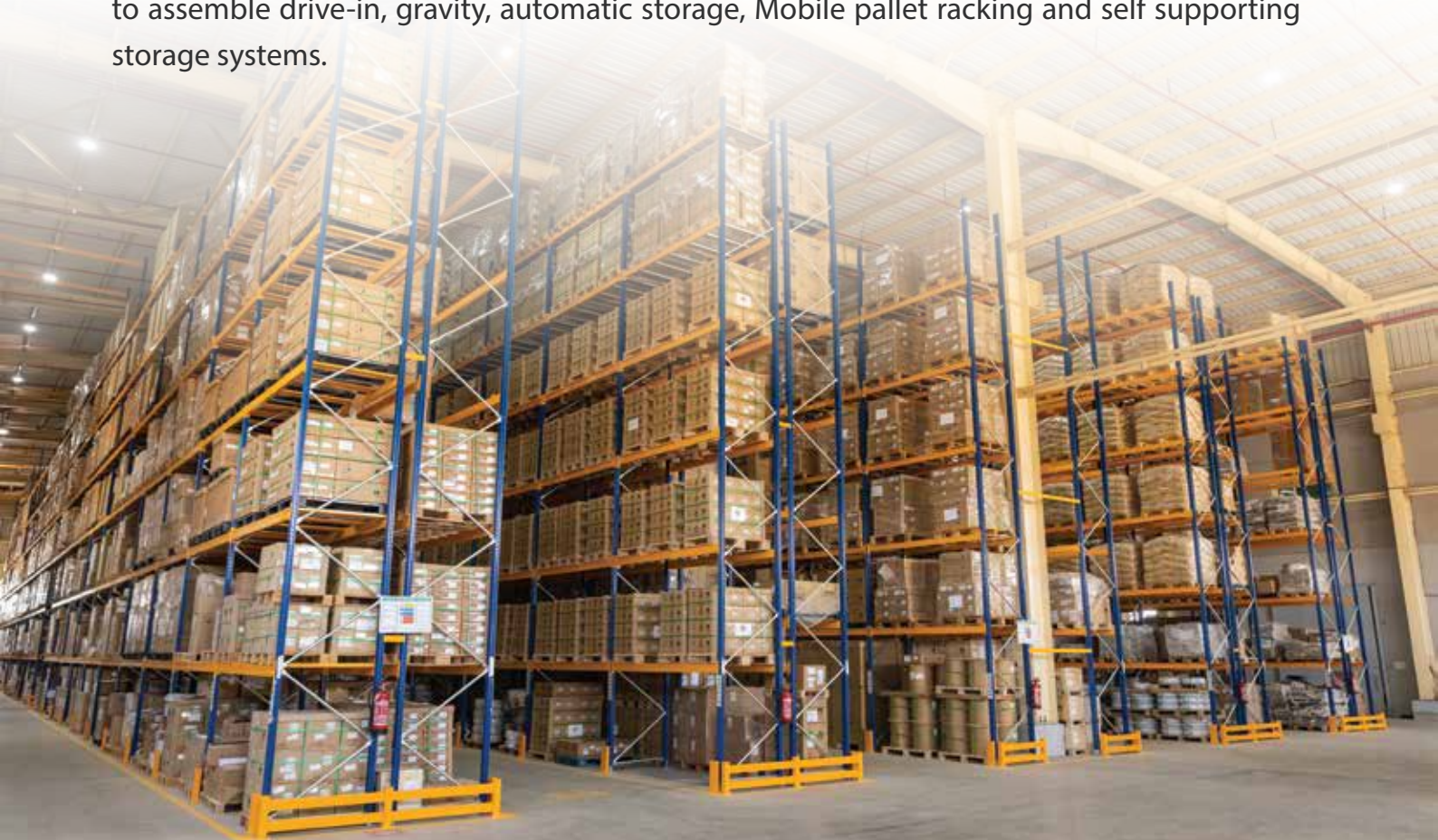

## Very Narrow Aisle racking (VNA) racking system

Narrow aisle racking or very narrow aisle (VNA) racking storage configuration allows companies to store more goods and materials per square foot within their warehouse or distribution center

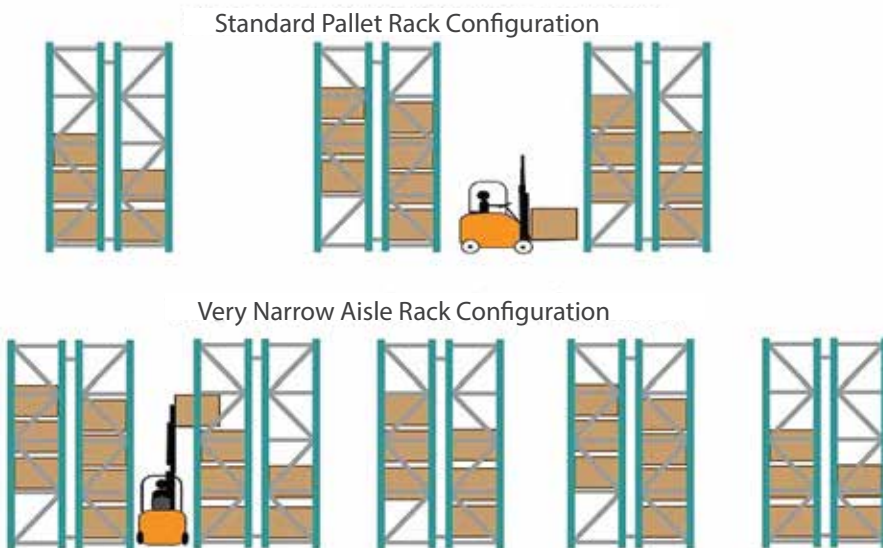

## Double Deep racking

Double-deep racks can be installed to store more pallets (depending on their weight and the pallets per SKU), enabling one pallet to be stored behind the other on each side of the aisle.

Direct access is only available to the first pallet. So, this system is recommended for storing products with multiple pallets per SKU.

This system requires suitable lifting machinery fitted with double-depth telescopic forks.



The most common conventional system comprises a single-entry rack fitted to the wall and double-entry racks in the middle

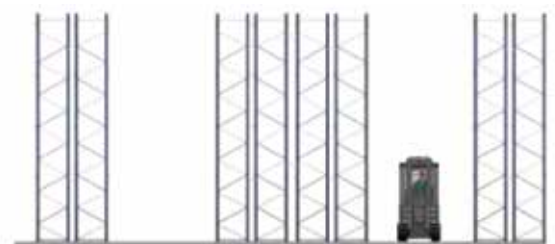

Double-deep conventional system

## Drive-In racking system

### Advantages

- The ideal solution for high capacity of homogenous products.
- Saving spaces by eliminating aisles between racking.



### Description

The drive-in solution works according to LIFO concept (last in- first out), meaning that the last unit to be stored is the first to be exit. Products are usually stored homogeneously in columns.

### Drive in picking types

- Drive –in system : Pallets are loaded and evacuated from one side of drive –in lane.
- Drive through system : Pallets are loaded and evacuated from both sides of drive–in lane thus this system has add on advantages that guarantees its stability and balance in case of loading and operation of the store.

This system is base on the storage by accumulation principle, which enables the highest use of available space in terms of both area and height.

Drive-in racking is designed for the storage of homogenous products. It accommodates a large number of pallets for each SKU.



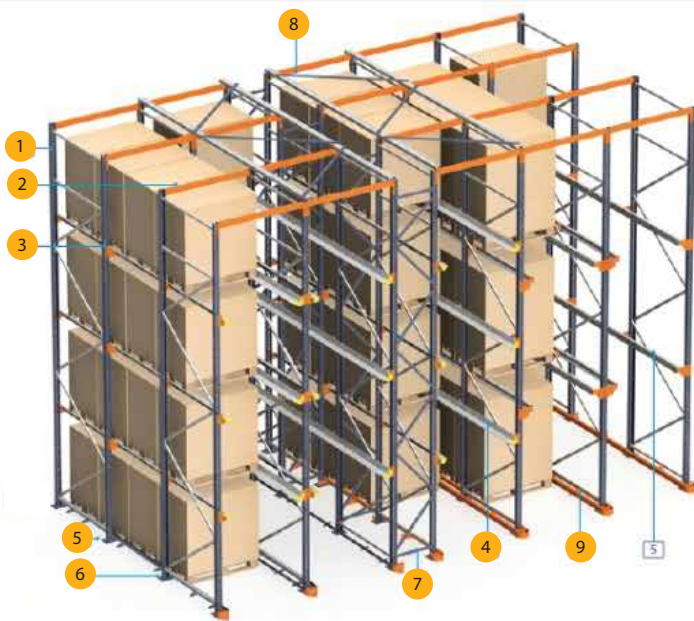

- 1 Frame
- 2 Drive-in beam
- 3 Bracket
- 4 GP rail
- 5 Leveling plates
- 6 Anchor bolts
- 7 Bracing set
- 8 Upper cross bracing
- 9 Guide rail ( optional )



## Pallet shuttle system

### Advantages

- Best solution for cold storage warehouses.
- Minimization the stuff accidents.
- High capacity warehousing.
- Reducing damage to racking system compared to (Drive-in system).
- High materials flow as each forklift can handle more than one shuttle.
- Scalability, that means the number of shuttle may be increased over time.

### Description

- Pallet shuttle system is facilitating the storing, picking and rearranging of pallets in various lanes according to LIFO principle and FIFO principle - In case of double access.
- It is the ideal solution to manage a multi-depth storage system for large quantities of pallets by item with high rotation frequency.
- The shuttle can be transported on forklift trucks and can be used in automated system.
- In high turnover operations. several shuttles can be operated above each other in the same aisle
- A shuttle equipped with lithium batteries for its operation, it can be guided into drive-in racks via remote control.
- In addition to standard version which is ideal for any environment and product sector Techno metal offers version of the shuttle suitable of cold storage operating temperatures up to -30 degree.



## Shuttle technical characteristics

- Maximum load : 1500 kg
- Load capacity : 1 pallet
- Maximum empty : 250 kg
- Speed on empty : 1,2 m/s
- Speed at full load : 0,6 m/s

Maximum Load Capacity	1500 kg (upon request up to 2000 kg)
Working Autonomy	from 8 to 10 Hours
Battery Recharge Time	2 Hours 30 Min
Number of Recharge Cycles	1200 cycles (FELIPO4 48V 33A)
Recharge Voltage & Frequency	220 V (50/60 HZ) - 110 V (60 HZ)
Battery Weight	16.5 kg
Recharge Type	Removable Battery



## Gravity system

### Advantages

- The best solution for the fast turnover of the stored products.
- Optimization of the space that required to the storage.
- Optimum stock management (The same product type stored in each channel).
- Minimization of pallet handling time as its movement due to its weight gravity.
- Reducing interference as the loading and unloading are in separate sides.

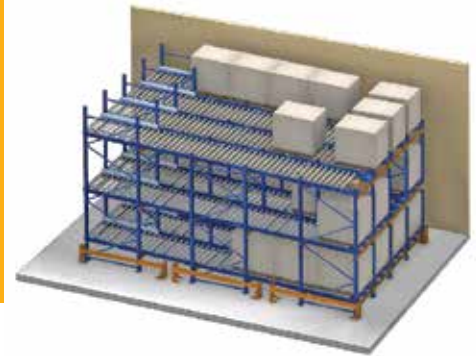

### Description

The materials are stored according to FIFO concept ( first in –first out),meaning that the first pallet stored is the first pallet to exit. an indispensable solution in the management of products with expiration dates. The gravity system are the ideal solution for storage of high capacity homogeneous products with high rotation frequency and are characterized by the presence of lanes on which loading units slide on rollers. The pallet is always aligned on the picking side, facilitating highly efficient handling operations.



This is an ideal system for warehouses of perishable goods, although it can also be used in any industry or distribution business.

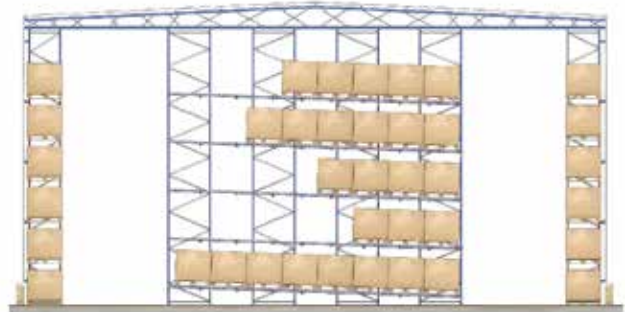



## Mezzanine structure system

### Advantages

- Multiplies surface space in industrial premises.
- Adaptable to the specific needs of the client, thanks to the great variety of sizes available, types of floors, construction systems, etc.
- Quick and easy assembly .
- They can be complemented with a variety of shelving system.



### Description

Mezzanine floors take maximum advantage of the height of premises, doubling or tripling the surface area and enabling it to be fitted out as a storage area. The installation of a mezzanine is an ideal solution to maximise the space available by taking advantage of the height of the building.

Mezzanine floors are totally dismantlable and re-usable, plus their structure, dimensions and location are easily modified.



## Multi-tier racking system

### Advantages

- Increasing the surface area.
- Assembling in fast and easy way.
- Extremely adaptable with high flexibility.
- Can be integrated with other existing storage systems.
- Suitable for the construction of offices.



### Description

The Multi-tier racking is a system that increases the storage area of warehouse and storage spaces. This long-span solution enables the installation of mezzanines with large open spaces free of columns. The beams structure are made of 8-fold sigmoid profiles, with thickness that vary upon the load bearing capacity needed, and are suitable for the installation of pipes and cables etc., The Multi-tier racking system is designed to be a load bearing structure, to meet all static and dynamic requirements that take into consideration the risk factors.



## Cantilever racking system

### Advantages

- Ideal system for long loads (beams -pipes -profiles -wooden blocks).
- Heavy loading simple structure.
- Shelves height easily changed.
- Available with full range of sizes and load bearing capacities.

### Description

Cantilever racking system is ideal for storing long goods or other bulky items. The list of products that can be stored ranges from plastic tubing, steel pipes , profiles and wooden planks to heavy coils. Cantilever uprights used as single-sided or dual-sided designs and the rows of uprights can be at any length required. The cantilever arms can be modified flexibly for stored goods with different heights and loading requirements. Subsequent adjustments and adaptations can be made without tools.

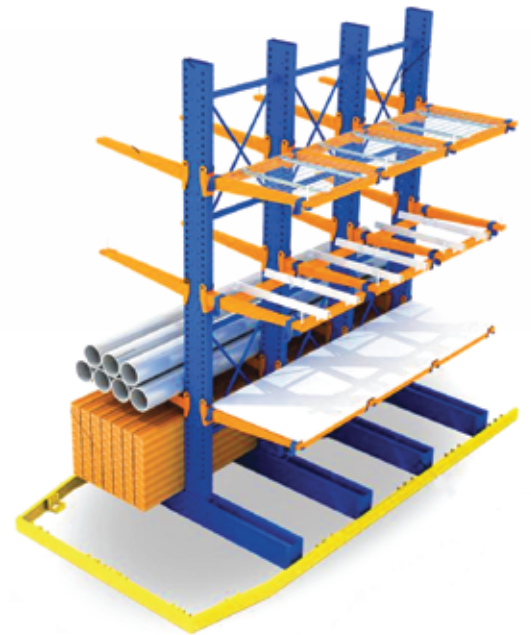



1. Column
2. Base
3. Arm
4. Arm stop
5. Cross bracing
6. Bracing set
7. Shim plate
8. Anchoring

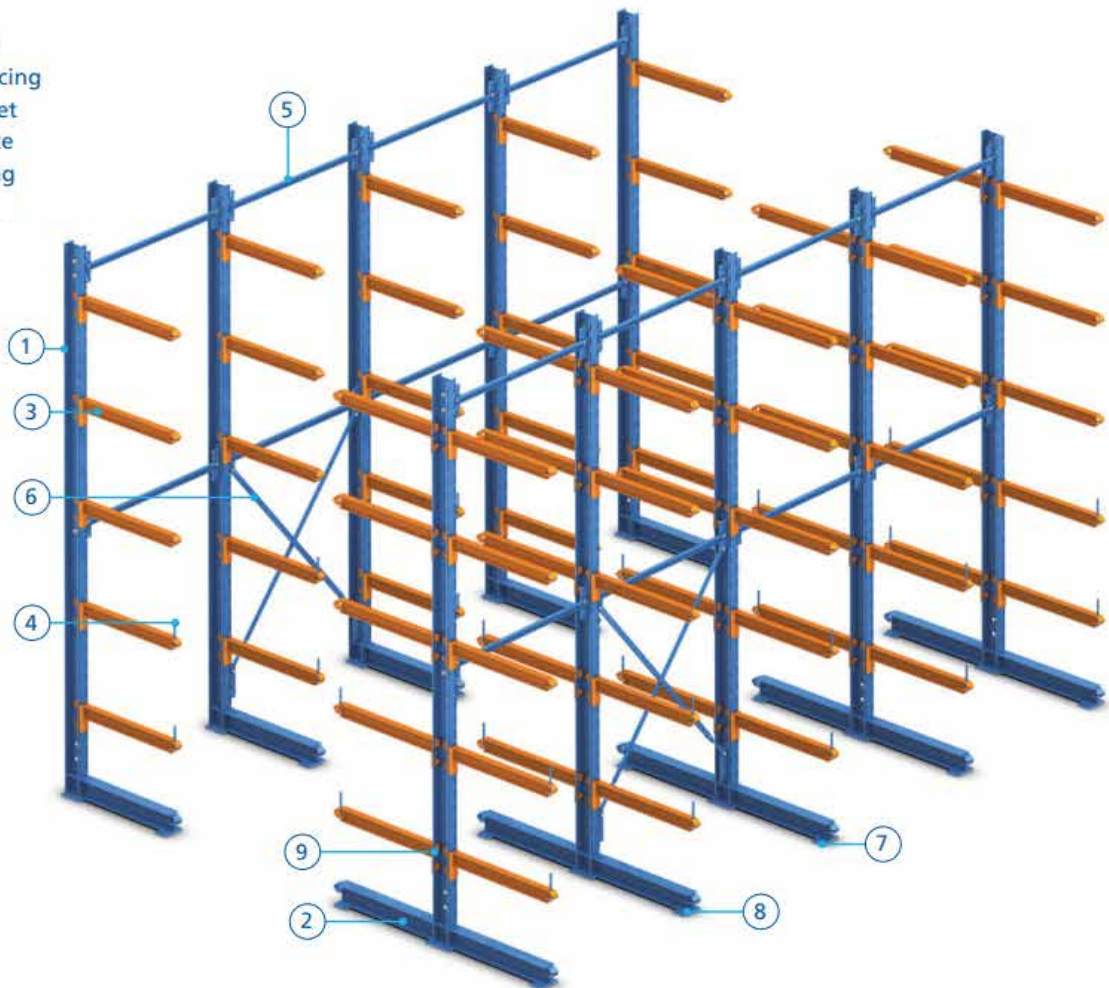

# Mobile pallet racking

## Advantages

- Motorized movement.
- Optimization of storage capacity.
- Suitable for cold storage.
- Can be integrated with automatic picking systems.
- High modularity for all types of storage.

## Description

Mobile pallet racking from ICAM saves considerable space as the number of aisles can be reduced to the minimum. Another advantages of this type of storage is that each pallet remains directly accessible. Mobile pallet racks are often used where storage space is expensive. The system consists of electrically driven mobile carriages supporting traditional or cantilever racking system, with shape and size define according to the stored materials and maximum utilization of available space.

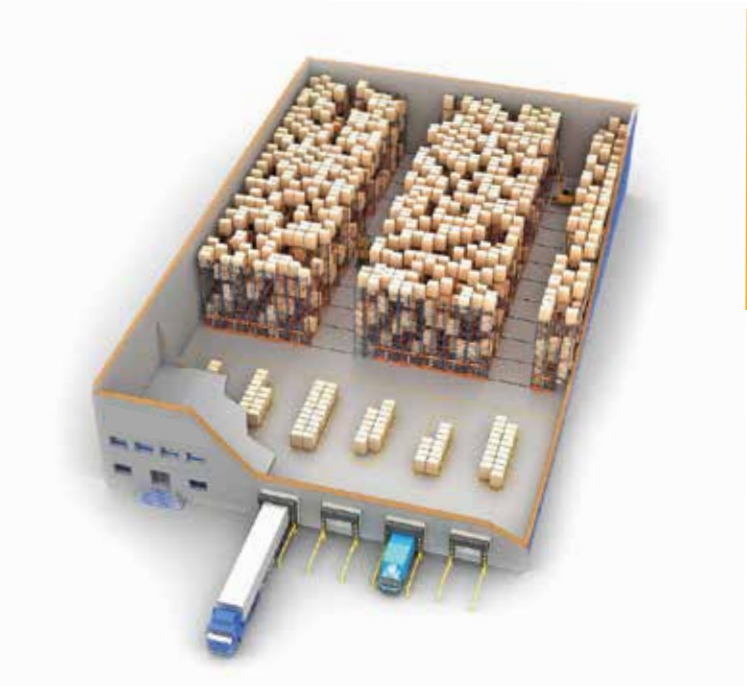

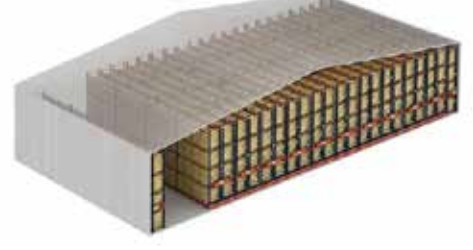
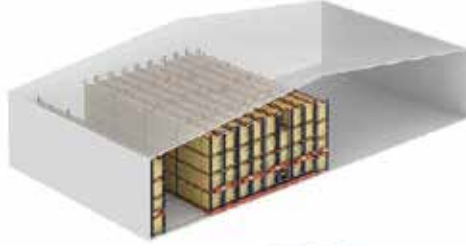
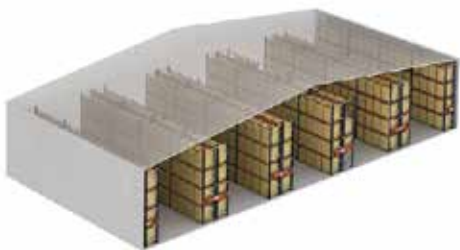
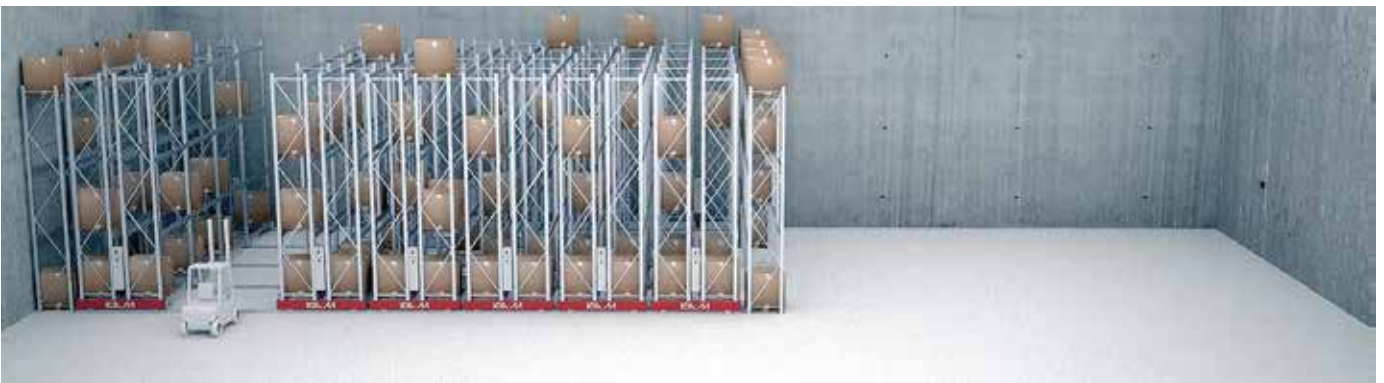
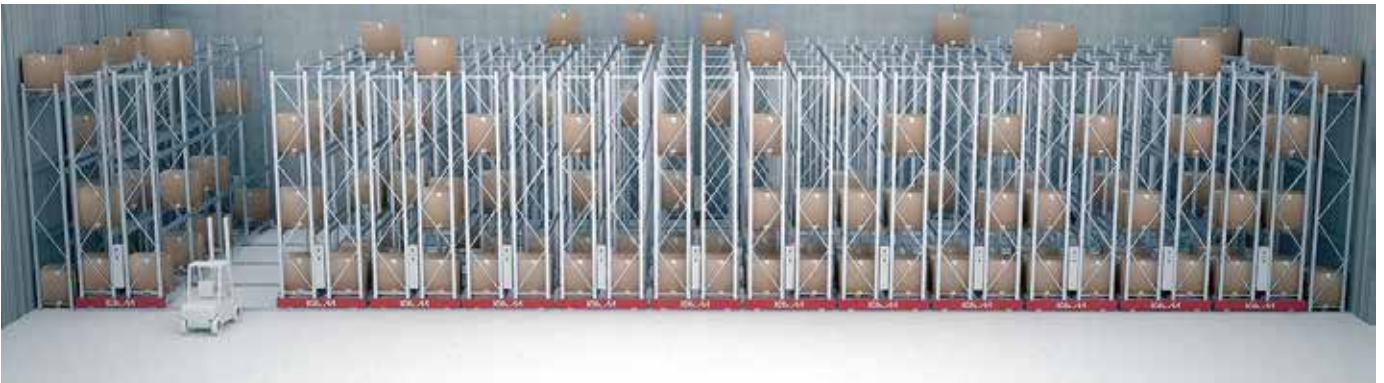

## Self support system (Rack-support building)

### Advantages

- Saves steel structure expenses.
- Enables using the maximum of available space.
- Allows a wide range of stored products (pallets, containers, bulky packages and very heavy loads) up to 12 meter.
- Reduction of construction time lines as erection of racks cladding and material.



### Description

Rack supported warehouses are structures almost entirely composed of high density storage systems which also function as the actual structural support for the facility.







## Automated vertical storage ( SILO2 - ICAM )

### Advantages

- Storage control.
- Ergonomics.
- Increasing productivity.
- Improve efficiency.
- Decreased footprint up to 1/10.
- Ideal for materials of different types, weight and size.
- Elimination of errors

### Description

The ideal solution for the storage and management of materials of any shape ,weight and size. It is made up of two sides of racks accommodating metal containers and served by a lift device. The flexible configuration allows the positioning of drawers at varying heights, depending on the type of unit load to be stored. This system has management software optimizes product distribution and handling . The storage system can be equipped with the Ergo-tech system – a further lift underneath the bay inside. the structure – which makes it possible to obtain the flows of dual-level bay.



## Mobile shelving system

### Advantages

- Optimization of space and storage capacity.
- Protection of filed materials.

### Description

Mobile shelving is a mobile filing system that slides on ground rails. This modular mobile system enables the amount of storage space to be doubled compared to traditional shelving solutions for any given space. Bases of mobile shelving are moved together using a crank or a single motor, meaning that just one single service aisle is required for easy access to all stored files or goods. The large number of shelving aisles saved costs significantly, because this solution reduces the floor area that required for the store, workshop or the warehouse, thus avoiding expensive plant extensions and optimizing your internal process



## Shelving units

### Description

It's a good combination of different units that permits universal solutions for sorting of light and medium duty items. These units can be used and placed in offices, schools, Shops, maintenance and automotive service centers. These units include office cupboard or document cabinet Drawer units for both boxes and lateral files in addition to slotted angle shelving units.



There are two kinds of shelving units:

- Light slotted angle
- Medium duty shelving units ( long span )



## Lockers

### Description

Our steel lockers are great way to provide durable personal. Storage of clothing , electronic devices and other items whether it's for staff in the workplace or for visitors at a leisure center, hospitals, clubs, schools ... etc.

Our steel lockers can be assembled in nest of 1 till nest of 6.

Lockers are available in a wide range of the following

- Size
- Door configuration
- Locking options
- Colors and finishes



## Some of Our Projects



Client : Ever life  
System : Pallet rack VNA  
Capacity : 9576 p.p



Client : MAERSK  
System : Drive in system  
Capacity : 1000 p.p



Client : EVA  
System : Pallet Rack system  
Capacity : 2493



Client : Noon  
System : Multi-tier system  
Capacity : 42000 shelves





Client : Jumia  
 System : slotted angle  
 Capacity : 1950



Client : Elsewedy  
 System : Cantilever system



Client : noon  
 System : Long Span



Client : Fourtex  
 System : Gravity system  
 Capacity : 424 P.P





CREATIVE  
RACKING  
SYSTEMS

# TECHNOMETAL

SHELVING & RACKING SYSTEMS

At the end,  
we are proud to provide you our products with the  
latest technologies, finest quality and international  
standards.

Thank You